

Three-phase multifunction energy meter

EXW4-100RS

User Guide V1.1



Safety Information

Important Information

Read these instructions carefully and look at the equipment to become familiar with the device before trying to install, operate, service or maintain it. The following special messages may appear throughout this bulletin or on the equipment to warn of potential hazards or to call attention to information that clarifies or simplifies a procedure.



The addition of either symbol to a “Danger” or “Warning” safety label indicates that an electrical hazard exists which will result in personal injury if the instructions are not followed.



This is the safety alert symbol. It is used to alert you to potential personal injury hazards. Obey all safety messages that follow this symbol to avoid possible injury or death.

DANGER

DANGER indicates an imminently hazardous situation which, if not avoided, will result in death or serious injury.

WARNING

WARNING indicates a potentially hazardous situation which, if not avoided, can result in death or serious injury.

CAUTION

CAUTION indicates a potentially hazardous situation which, if not avoided, can result in minor or moderate injury.

NOTICE

NOTICE is used to address practices not related to physical injury. The safety alert symbol shall not be used with this signal word.

Please Note

Electrical equipment should be installed, operated, serviced, and maintained only by qualified personnel. No responsibility is assumed by Nova for any consequences arising out of the use of this material.

A qualified person is one who has skills and knowledge related to the construction, installation, and operation of electrical equipment and has received safety training to recognize and avoid the hazards involved.

Table of Contents

Chapter 1. Overview	- 1 -
1.1. Introduction.....	- 1 -
1.2. Characteristics	- 1 -
1.3. Parameters.....	- 1 -
Chapter 2. Technical parameters specification.....	- 2 -
2.1. Specification.....	- 2 -
2.2. Installation dimensions.....	- 4 -
2.3. Wiring Diagrams.....	- 4 -
Chapter 3. General function description	- 5 -
3.1. Multi-tariffs function.....	- 5 -
3.2. Demand calculation method.....	- 6 -
Chapter 4. Operation	- 6 -
4.1. Meter startup instructions	- 6 -
4.2. LCD display area description	- 7 -
4.3. Button definition description	- 8 -
4.4. Description of display screen	- 8 -
4.4.1. Main display screen.....	- 8 -
4.4.2. Auxiliary display screen	- 12 -
4.5. Setting-up	- 14 -
4.5.1. Set communication class parameters.....	- 15 -
4.5.2. Set system class parameters.....	- 16 -
4.5.3. Set pulse output class parameters.....	- 18 -
4.5.4. Set demand class parameters	- 19 -
4.5.5. Set time class parameters.....	- 20 -
Appendix	- 24 -
Appendix A – LCD character definition table	- 24 -
Appendix B – Failure code reference table	- 24 -
Appendix C – Alarm prompt comparison table	- 24 -

Chapter 1. Overview

1.1. Introduction

EXW4-100RS is a three phase DIN rail installation multi-function energy meter. This series of products can support measurement and analysis of variety of power parameters, such as voltage, current, the four quadrant power parameters, power factor, harmonic content etc. ; Meanwhile they also can provide the measurement of multiple electric energy parameters , such as two way active energy, reactive energy, monthly and daily electricity consumption statistics. This series of products also can support the analysis of electric power parameter measurement in 1P2W, 3P4W, 3P3W grid environment, is suitable for power monitoring for photovoltaic inverter , new energy electricity consumption statistic analysis, real time power monitoring and a variety of other environments, has the multi-function, high stability and long life characteristics. This series of products with RS485 or MBUS communication interface, baud rate maximum support 38400bps, supporting Modbus, MBUS communication protocols. It can easily realize the function of remote data read, and adopt the design of large-screen LCD and touch-sensitive key, which can easily carry out the local view and set operation of variety parameters. The product has the function of password protection, which ensures the data security of the product.

EXW4-100RS is a multi-functional electric energy meters designed for electric energy monitoring of photovoltaic inverter, statistical analysis of new energy electricity consumption, power monitoring needs of power system utilities and intelligent buildings. Its complete communication function is very suitable for various control systems, SCADA systems and energy management systems.

- ### 1.2. Characteristics
- Maximum current **100A direct access**
 - DIN Rail mounting, standard 4 modulus width.
 - Touch button design improves button operability and reduces button failure rate
 - Multi-function parameter measurement, providing voltage, current, active power, reactive power, apparent power, power factor, phase Angle, etc.
 - To provide the analytical data of the total harmonic contents of voltages and currents
 - Provide a variety of statistical data and local storage functions, such as two-way power, demand and other statistical data. Provide monthly electricity consumption statistics for the last 12 months and daily electricity consumption statistics for the last 31 days
 - supports the dual-timing function of the meter startup running time and load running time.
 - supports the access of a 2-tariff switching signal for metering at 2-tariff energy.
 - Support RS485 communication function, baud rate up to 38400bps, support Modbus RTU protocol.
 - Supports one optocoupler pulse output interface, and output parameters can be set.
 - LCD refresh time is 1 second, support manual or automatic scroll display (configurable)

1.3. Parameters

1. The Unit can measure and display	
Instantaneous RMS Values	
Current	Per phase, neutral

Voltage	L-L, L-N
Frequency	45 to 65Hz
Active power	Total and per phase
Reactive power	Total and per phase
Apparent power	Total and per phase
Power factor	Total and per phase
Energy Values (include: import, export, import + export)	
Active energy	0 to 9999999.999 kWh
Reactive energy	0 to 9999999.999 kvarh
Multi-Tariff active energy (T1 - T4)	0 to 9999999.999 kWh
Maximum Demand Values	
Max.Demand of current	Per phase
Max.Demand of active power	Total
Max.Demand of reactive power	Total
Max.Demand of apparent power	Total
2. The Unit can measure and communication read	
Energy Values	
Apparent Energy (total)	0 to 9999999.999 kVAh
Per phase energy	Active energy and reactive energy, include: import, export, import+export Range: 0 to 999999.999 kWh/kvarh
Multi-Tariff reactive energy (T1 - T4)	0 to 9999999.999 kvarh, include: import, export, import+export
Monthly electricity consumption for the last 12 months	Total active energy Range: 0 to 9999999.999 kWh
Daily energy consumption for the last 31 days	Total active energy Range: 0 to 9999999.999 kWh
3. The Unit can settable	
Communication class	Modbus address, baud rate, parity bit, stop bit
System configuration class	User password (HMI), Power system type
Demand class	Demand interval period, Slide time
Pulse output class	Pulse output type, Pulse output width, Pulse output rate
Time class	Automatic scroll display time, Backlit time, System time (RTC), Tariff time

Chapter 2. Technical parameters specification

2.1. Specification

Electrical Characteristics		
Type of measurement		RMS including harmonics on AC system, support 1P2W, 3P3W, 3P4W
Measurement accuracy	Voltage, Current	Class 0.5, according IEC 61557-12
	Active power	Class 0.5, according IEC 61557-12
	Reactive power	Class 2, according IEC 61557-12
	Apparent power	Class 1, according IEC 61557-12
	Active energy	Class 0.5S, according IEC 62053-22, IEC 61557-12
	Reactive energy	Class 2, according IEC 62053-23, IEC 61557-12
	Power factor	Class 1, according IEC 61557-12

	Frequency	Class 0.2, according IEC 61557-12
	Harmonic distortion	Class 2, according IEC 61557-12
Data update rate		1 second. Optional 100 ms
Input-Voltage	Rate voltage (Un)	230 Vac (L-N) / 400 Vac (L-L)
	Direct connection	Measured range : 85 to 270 Vac (L-N), 85 ~ 480 Vac (L-L)
	Frequency range	45 to 65 Hz
	Overload capacity	2*Un for 1 second
Input-Current	Measured range	0.005 to 100 A, basic current (Ib) is 5A
	Overload capacity	30*I _{max} for 0.01 second
Pulse output	Interface type	Open collector optocoupler
	Pulse constant	400 / 100 / 10 / 1 imp/kWh(kvarh) (Configurable)
	Pulse width	60/100/200 milliseconds (Configurable), default is 100milliseconds
	Pulse output type	Import/export/total active energy, Import/export/total reactive energy (Configurable)
	Class	Class A, according IEC 62053-31
	Input voltage	5 ~ 27 Vdc
Pulse indicator light on the panel		Pulse constant is 400imp/kWh
Real-time clock accuracy		0.5 s/d
Mechanical Characteristics		
IP Degree of Protection (IEC 60529)		Designed to IP51 front display, IP30 meter body
Dimensions (W x H x D)		72 x 100 x 66 mm
Mounting Position		DIN Rail mounting
Material of meter case		UL 94 V-0
Environmental Characteristics		
Operating Temperature		-25 to +55°C
Storage Temperature		-40 to +80°C
Humidity		< 90%, non-condensing
Pollution Degree		2
Altitude		Up to 2000m
Vibration		10 Hz to 150Hz, IEC 60068-2-6
Electromagnetic Characteristics		
Electrostatic Discharge		Level 4, according IEC 61000-4-2 ⁽¹⁾
Immunity to Radiated Fields		Level 3, according IEC 61000-4-3 ⁽¹⁾
Immunity to Electrical Fast Transients		Level 4, according IEC 61000-4-4 ⁽¹⁾
Immunity to Surges		Level 4, according IEC 61000-4-5 ⁽¹⁾
Immunity to Conducted Disturbances		Level 3, according IEC 61000-4-6 ⁽¹⁾
Immunity to Magnetic Fields		IEC 61000-4-8 ⁽¹⁾
Immunity to Voltage Dips		IEC 61000-4-11 ⁽¹⁾
Radiated Emissions		Class B, according EN55011
Conducted Emissions		Class B, according EN55011
Harmonics		IEC 61000-3-2 ⁽¹⁾
(1): The experimental test is carried out according to the grade requirements of industrial grade products in IEC61326-1		
Safety		
Measurement Category		CAT III, according IEC 61010-1

Overvoltage Category	CAT III, according IEC 61010-1
Insulation	AC Voltage Test: 4kV for 1 minute
	Impulse Voltage Test: 6kV - 1.2/50 μ S waveform
Protective Class	II, according IEC61010-1
Communications	
Interfaces standard and protocols	2-wire RS485, Modbus RTU Optional: MBus
Buad rate	1200 to 38400 bps, default is 9600 bps
Parity bit	None, Even, Odd, default is None
Stop bit	1 or 2, default is 1
Response time	<100ms
Transmission mode	half-duplex
Transmission distance	Up to 1000m
Max. Bus loading	64 pcs

2.2. Installation dimensions

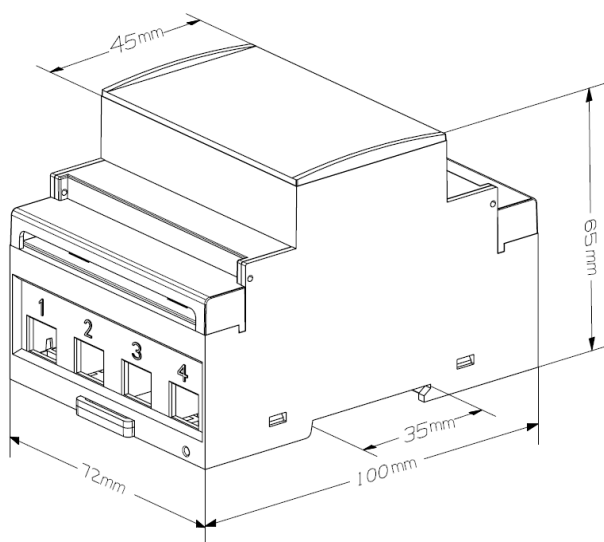

2.3. Wiring Diagrams

Measurement input wiring	
3P4W	3P3W
<p>Diagram for 3P4W: A central box represents the device. On the left side, terminals 1, 2, 3, and 4 are labeled 'LOAD' and 'OUT'. On the right side, terminals 5, 6, 7, and 8 are labeled 'IN' and 'L1', 'L2', 'L3', and 'N' respectively.</p>	<p>Diagram for 3P3W: A central box represents the device. On the left side, terminals 1, 2, 3, and 4 are labeled 'LOAD' and 'OUT'. On the right side, terminals 5, 6, 7, and 8 are labeled 'IN' and 'L1', 'L2', 'L3', and 'L2' respectively.</p>
1P2W	2P3W

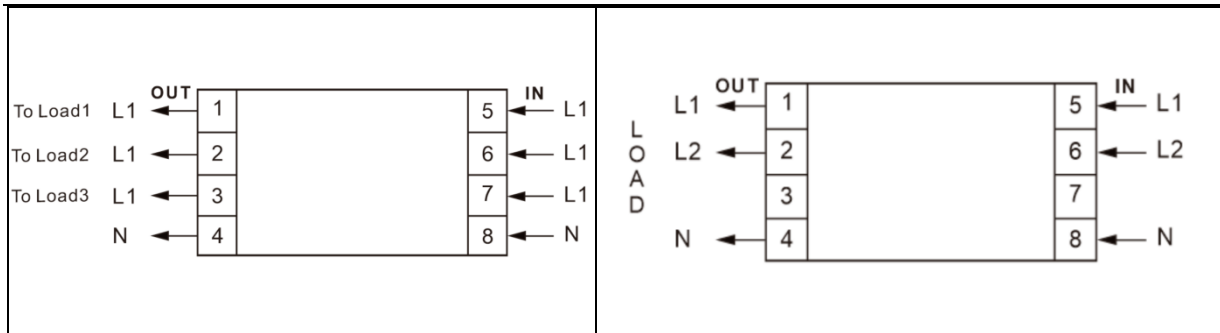

Communication terminal wiring

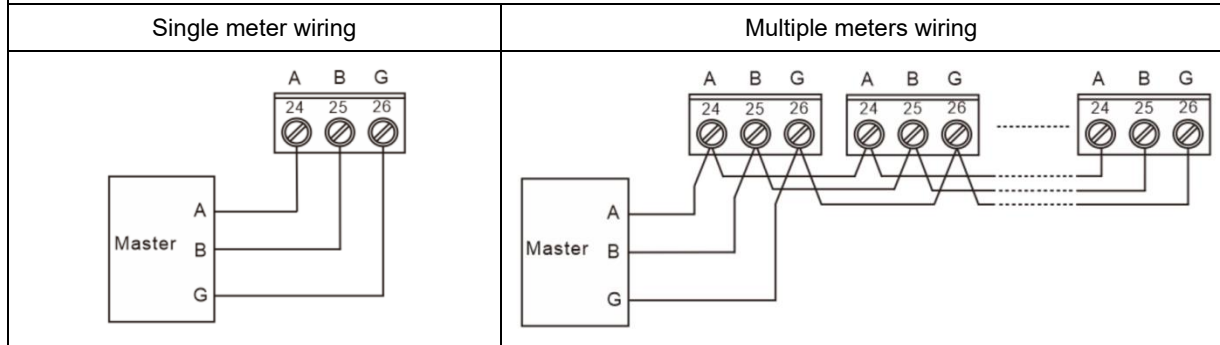

Pulse output terminal wiring

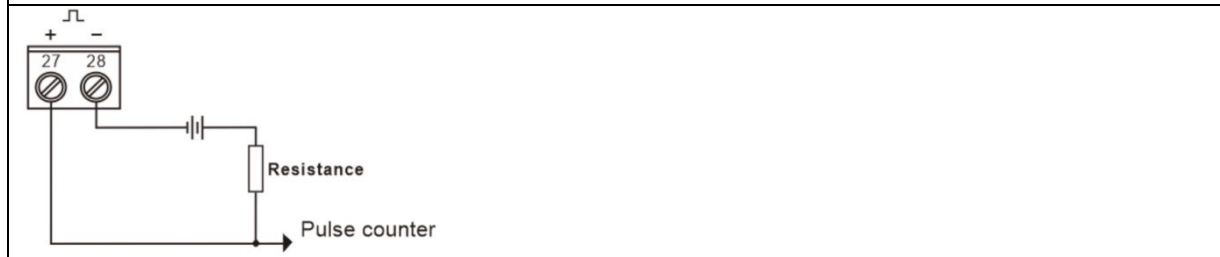

2-tariff switch terminal wiring



Chapter 3. General function description

3.1. Multi-tariffs function

The multi-tariffs function refers to the function that the meter realizes time-sharing measurement of electric quantity. The power meter divides the 24 hours of a day into several time periods, and then specifies the rate number for each time period. Then the power meter accumulates the amount of electricity in time division according to the pre-divided time period, and stores it to the position of the rate number corresponding to each time period, so as to realize the function of time-division measurement of electricity.

The meter used the method of the tariff number correlation to the starting time point to realize the

tariff segment division. The power meter support up to 8 starting time points and up to 4 tariff segments (T1, T2, T3 and T4).

Figure 3-1: The starting time points of the tariff segment

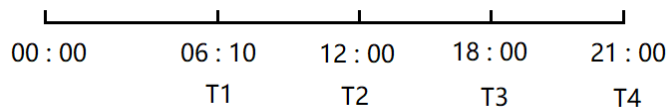

As shown in Figure 3-1, 06:10 designated as the start time of tariff 1 (T1), 12:00 designated as the start time of tariff 2 (T2), 18:00 designated as the start time of tariff 3 (T3), 21:00 designated as the start time of tariff 4 (T4), so tariff 1 time range is 06:10 to 12:00, tariff 2 time range is 12:00 to 18:00, tariff 3 time range is 18:00 to 21:00, tariff 4 time range is 21:00 to tomorrow 06:10.

Note: The tariff parameters can be set by communication commands (Please refer to the relevant communication protocol document for the register address).

3.2. Demand calculation method

The block intervals are sliding, the power meter calculates and update the demand at the sliding speed.

Figure 3-2: Diagram of sliding block interval calculation method

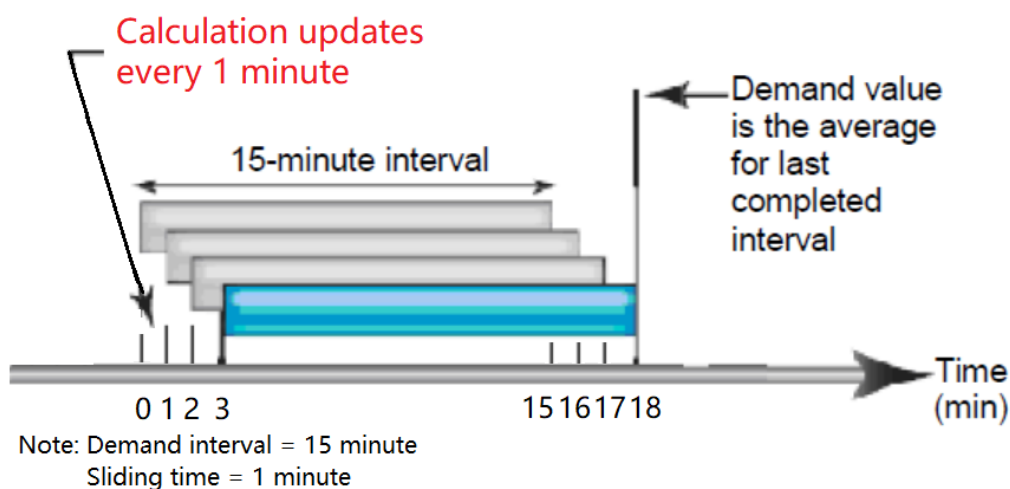



As shown in Figure 3-2, the first demand calculation is made at the 15th minute, and the demand calculation data is between the 0th and the 15th minute. At the 16th minute, do the second demand calculation, and the demand calculation data is between the 1th and the 16th minute. At the 17th minute, do the third demand calculation, and the demand calculation data is between the 2th and the 17th minute.

Chapter 4. Operation

4.1. Meter startup instructions

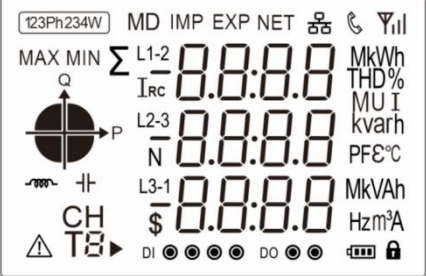
After the EXW4-100RS is properly wired and connected to the power supply, the products will first enter the self-test process, under which the LCD screen display sequence is shown as follows:

First screen display	Display full screen characters	
Second screen display	Displays the software version number of the power meter	
Three screen display	Display the results of the self-test	

4.2. LCD display area description

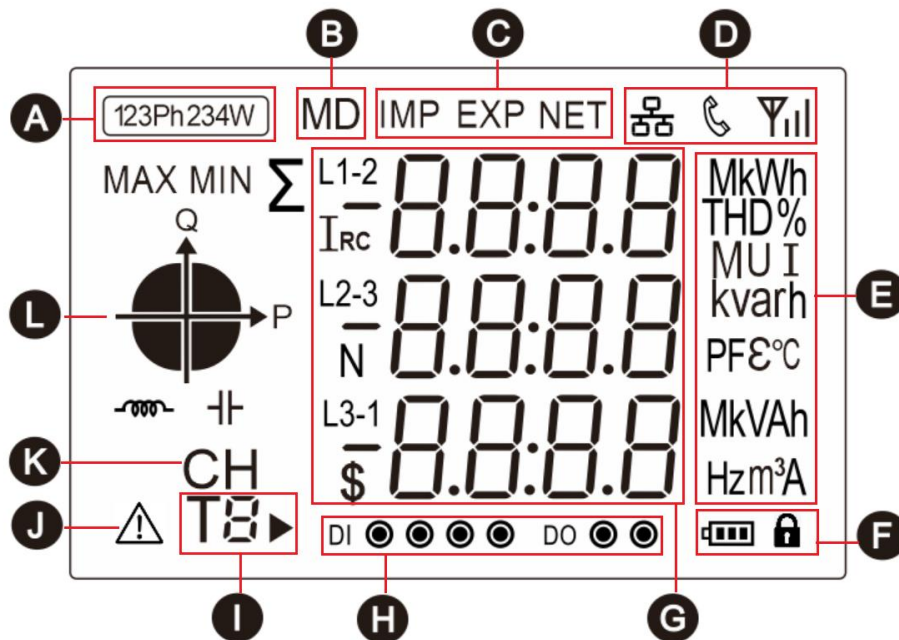

- A: The power grid type icon represents the current measurement type of the meter.
- B: Maximum demand icon.
- C: Direction icon for import and export energy.
- D: A status indicator icon for the meter.
- E: An icon of a unit of measurement data.

F: Battery status Icon and lock icon, displays the battery status and dicates that the device is locked.

G: Measured values.

H: An icon of digital I/O status for the meter.





I: Multi tariff icon indicating the tariff segment to which the current energy. ► represents the tariff number displayed as the running tariff segment. For example: **T2** ► The figure on the left represents that the tariff 2 (T2) segment is running, and the accumulated energy will be counted into the corresponding energy area of tariff 2 (T2).

J: Warning Status icon.

K: Channel indicator icon for multiple measurement channels.

L: Quadrant indicator icon indicating the quadrant of the current load.

4.3. Button definition description

Button	Definition	Click	Press 3 second
	Button 1: Escape key (Esc)	1. In the setting screen or auxiliary screen: exit or return to the previous screen. 2. In the main display screen: page scroll for parameters such as voltage and current.	Under the main display screen: enter the auxiliary display screen.
	Button 2: Up key (Up)	1. In the main display screen: view the power factor, maximum demand. 2. In the setting screen or auxiliary screen: scroll up to display the page or the increasing number.	Null
	Button 3: Down key (Dn)	1. In the main display screen: veiw the power information. 2. In the setting screen or auxiliary screen: scroll down to display the page or the decreasing number.	Null
	Button 4: Enter key (Et)	1. In the main display screen: veiw energy data and system time. 2. In the setting screen: right move the setting cursor.	1. In the main display screen: enter the setting mode. 2. In the setting screen: enter the setting state or carry out confirmation operation.

4.4. Description of display screen

4.4.1. Main display screen

After the meter is powered on and passes the self-test process, the interface entered is defined as the main display interface, which is used to display the main measurement parameters, electric quantity data, instrument information and other data of the product. Users can scroll the display

page by pressing the button 1 to button 4.

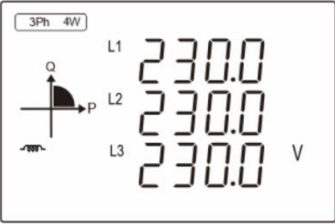
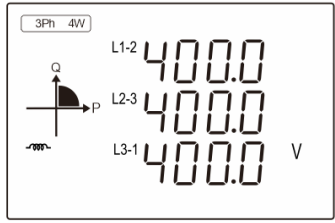
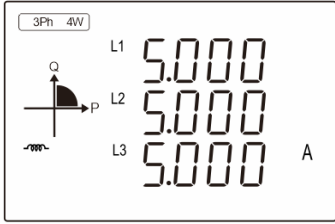
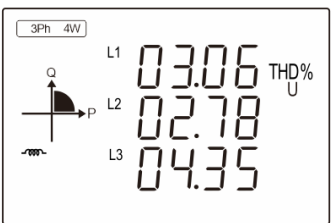
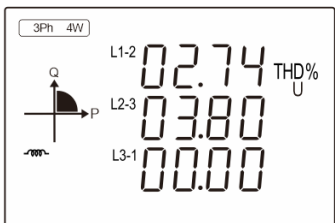
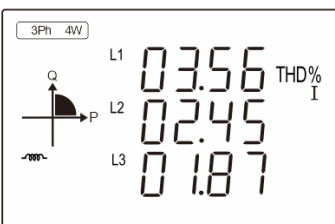
LCD display	Description
Display screen under button 1	
	<p>A display screen for three-phase L-N voltage.</p> <p>Example: L1-N voltage = 230.0V L2-N voltage = 230.0V L3-N voltage = 230.0V</p> <p>Note: In 3P3W mode, this screen is not displayed</p>
	<p>A display screen for three-phase L-L voltage.</p> <p>Example: L1-2 voltage = 400.0V L2-3 voltage = 400.0V L3-1 voltage = 400.0V</p> <p>Note: In 1P2W mode, this screen is not displayed</p>
	<p>A display screen for three-phase current.</p> <p>Example: L1 current = 5.001A L2 current = 5.002A L3 current = 5.000A</p>
	<p>A display screen for three-phase L-N voltage THD.</p> <p>Example: L1 voltage THD = 3.06% L2 voltage THD = 2.78% L3 voltage THD = 4.35%</p>
	<p>A display screen for three-phase L-L voltage THD.</p> <p>Example: L1-2 voltage THD = 2.74% L2-3 voltage THD = 3.80% L3-1 voltage THD = 0.00%</p> <p>Note: This screen is displayed only in 3P3W mode.</p>
	<p>A display screen for three-phase current THD.</p> <p>Example: L1 current THD = 3.56% L2 current THD = 2.45% L3 current THD = 1.87%</p>



Display screen under button 2	
	<p>Total power factor and frequency display screen</p> <p>Example: Total power factor = 1.000 Frequency = 50.00Hz</p>
	<p>Three - phase power factor display screen</p> <p>Example: L1 power factor = 1.000 L2 power factor = 1.000 L3 power factor = 1.000</p>
	<p>Max.demand of three-phase display screen</p> <p>Example: Max.Demand of L1 current = 5.000A Max.Demand of L2 current = 5.000A Max.Demand of L3 current = 5.000A</p>
	<p>Max.demand of total active/reactive/apparent power display screen</p> <p>Example: Max.Demand of total active power = 3.680 kW Max.Demand of total reactive power = 5.701 kvar Max.Demand of total apparent power = 3.598 kVA</p>
Display screen under button 3	
	<p>Per phase active power display screen</p> <p>Example: L1 active power = 1.150 kW L2 active power = 1.150 kW L3 active power = 1.150 kW</p>
	<p>Per phase reactive power display screen</p> <p>Example: L1 reactive power = 0 kvar L2 reactive power = 0 kvar L3 reactive power = 0 kvar</p>
	<p>Per phase apparent power display screen</p> <p>Example: L1 apparent power = 1.150 kVA L2 apparent power = 1.150 kVA L3 apparent power = 1.150 kVA</p>

	<p>Total active/reactive/apparent power display screen</p> <p>Example: Total active power = 3.450 kW Total reactive power = 0 kvar Total apparent power = 3.450 kVA</p>
<p>Display screen under button 4</p>	
	<p>Total active energy</p> <p>Example: Total active energy = 30.10 kWh</p>
	<p>Import active energy</p> <p>Example: Import active energy = 15.05 kWh</p>
	<p>Export active energy</p> <p>Example: Export active energy = 15.05 kWh</p>
	<p>Tariff 1 active energy</p> <p>Example: Tariff 1 active energy = 63.42kWh</p> <p>Note: Only mult-tariff meter and 2T meter show this page</p>
	<p>Tariff 2 active energy</p> <p>Example: Tariff 2 active energy = 28.63kWh</p> <p>Note: Only mult-tariff meter and 2T meter show this page</p>
	<p>Tariff 3 active energy</p> <p>Example: Tariff 3 active energy = 83.55kWh</p> <p>Note: Only mult-tariff meter show this page</p>

<p>3Ph 4W Q P T4</p>	<p>Tariff 4 active energy</p> <p>Example: Tariff 4 active energy = 93.26kWh</p> <p>Note: Only mult-tariff meter show this page</p>
<p>3Ph 4W Q P Σ</p>	<p>Total reactive energy</p> <p>Example: Total reactive energy = 2363.49kvarh</p>
<p>3Ph 4W Q P IMP</p>	<p>Import reactive energy</p> <p>Example: Import reactive energy = 2300.26kvarh</p>
<p>3Ph 4W Q P EXP</p>	<p>Export reactive energy</p> <p>Example: Export reactive energy = 63.23kvarh</p>
<p>3Ph 4W Q P</p>	<p>Displaying the current date of the system real-time clock.</p> <p>Example: The current date is June 4, 2021</p> <p>Note: Only mult-tariff meter show this page</p>
<p>3Ph 4W Q P</p>	<p>Displaying the current time of the system real-time clock.</p> <p>Example: The current time is 14:32.38</p> <p>Note: Only mult-tariff meter show this page</p>
<p>Icon description of the load nature:</p>	
<p>is mean : The load is an inductive load ,</p>	<p>is mean : The load is a capacitive load.</p>

4.4.2. Auxiliary display screen

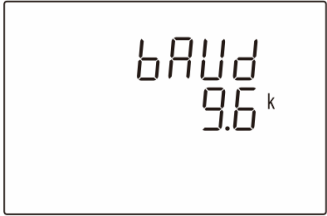
Under the main display screen, press button 1 for 3 second to enter the screen of auxiliary display. At this point, click button 2 or button 3 can be scroll the page needs to be viewed. Under the screen of auxiliary display, can click button 1 to return to the main display screen. If there is no button operation in more than 1 minute under the screen of auxiliary display, the meter will automatically return to the main display screen.

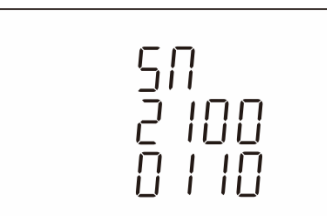
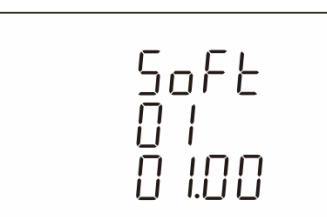
LCD display	Description
	Modbus address Example: The modbus address is 1.
	Baud rate Example: The baud rate is 9600bps.
	Parity bit Example: The Parity bit is None.
	The serial number of meter Example: The serial number is 21000110.
	Software version number

4.5. Setting-up

The logical diagram of the parameter setting menu is as follows:

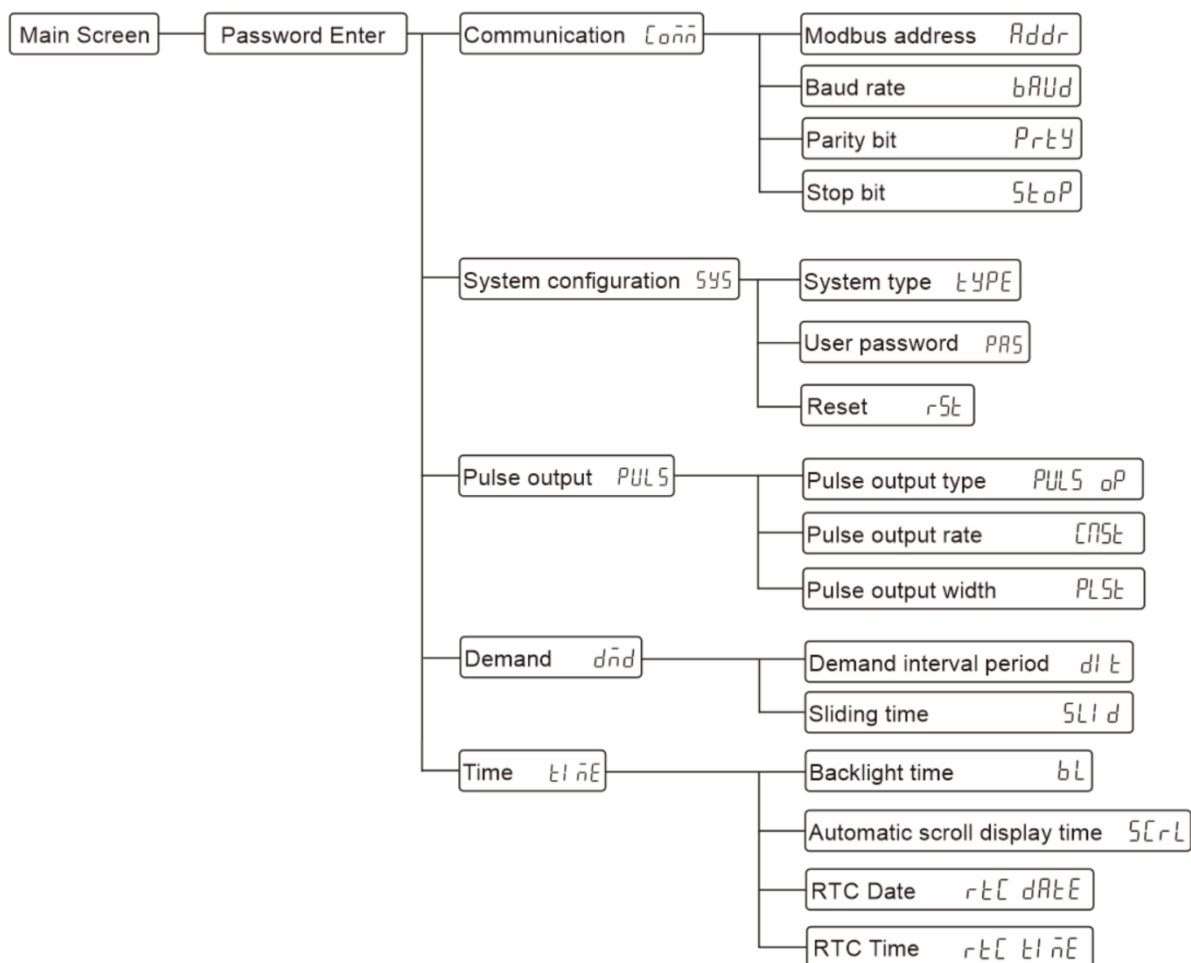

How to enter the "Parameter setting Menu" screen:

Step 1: In the main display screen, press button 4 for 3 second to enter the user password input mode.

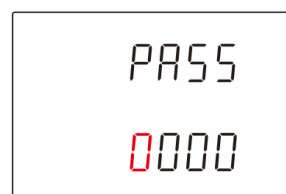

Note: The user password input screen is shown in the figure on the right.

Step 2: Enter the correct user password and press button 4 for 3 second to confirm.

How to enter a password:

A: Click button 2 and button 3 to increase or decrease the number of flashing bits.

B: Click button 4 to move the flashing position to the right.

C: After entering the correct password, press button 4 for 3 second for confirmation. If the password is verified correctly, the power meter will enter the screen of "Parameter Setting menu".





Note: Under the user password input screen, can click button 1 to return to the main display screen. If there is no button operation in more than 1 minute under this screen, the power meter will automatically return to the main

display screen.

4.5.1. Set communication class parameters

Communication parameters include: Modbus address, baud rate, parity bit, stop bit.

<p>1. After entering the "Parameter Setting Menu" screen, select the setting screen (as shown in the figure below), and then press button 4 for 3 second to enter the communication parameter setting screen.</p>	
<p>2. Setting the modbus communication address</p>	
	<p>Modbus address setting range: 001 to 247, default is 001.</p> <p>Press button 4 for 3 second to enter the setting state, and the digit of the setting becomes the flashing state.</p> <p>Click button 2 or button 3 to scroll the page and select the next setting interface.</p> <p>Click button 1 to exit the setting menu and return to the previous setting screen.</p>
	<p>Click button 2 or button 3 to increase or decrease the number of set bits.</p> <p>Click button 4 can be moved the set bits to the right.</p> <p>Press button 4 for 3 second to confirm the setting. The meter will save the setting value and exit the setting state.</p> <p>Click button 1 to exit the setting state without saving the setting parameters.</p>
<p>3. Setting the baud rate</p>	
	<p>Baud rate can be setting: 1200, 2400, 4800, 9600, 19200, 38400 bps, default is 9600bps.</p> <p>Press button 4 for 3 second to enter the setting state, and the digit of the setting becomes the flashing state.</p> <p>Click button 2 or button 3 to scroll the page and select the next setting interface.</p> <p>Click button 1 to exit the setting menu and return to the previous setting screen.</p>
	<p>Click button 2 or button 3 to select the baud rate.</p> <p>Press button 4 for 3 second to confirm the setting. The meter will save the setting value and exit the setting state.</p> <p>Click button 1 to exit the setting state without saving the setting parameters.</p>
<p>4. Setting the parity bit</p>	

	<p>Parity bit can be setting: None, Even, Odd, default is None.</p> <p>Press button 4 for 3 second to enter the setting state, and the character of the setting becomes the flashing state.</p> <p>Click button 2 or button 3 to scroll the page and select the next setting interface.</p> <p>Click button 1 to exit the setting menu and return to the previous setting screen.</p>
	<p>Click button 2 or button 3 to select the parity bit.</p> <p>Press button 4 for 3 second to confirm the setting. The meter will save the setting value and exit the setting state.</p> <p>Click button 1 to exit the setting state without saving the setting parameters.</p>
<p>5. Setting the stop bit</p>	
	<p>Stop bit can be setting: 1 or 2, default is 1.</p> <p>Press button 4 for 3 second to enter the setting state, and the digit of the setting becomes the flashing state.</p> <p>Click button 2 or button 3 to scroll the page and select the next setting interface.</p> <p>Click button 1 to exit the setting menu and return to the previous setting screen.</p> <p>Note: The stop bit can only be set to 2 if the check bit is equal to None.</p>
	<p>Click button 2 or button 3 to select the stop bit.</p> <p>Press button 4 for 3 second to confirm the setting. The meter will save the setting value and exit the setting state.</p> <p>Click button 1 to exit the setting state without saving the setting parameters.</p>

4.5.2. Set system class parameters

System class parameters include: system type, user password, reset max. demand or historical electricity consumption log.

<p>1. After entering the "Parameter Setting Menu" screen, select the setting screen (as shown in the figure below), and then press button 4 for 3 second to enter the system class parameter setting screen.</p> 
--

<h2>2. Set system type</h2>	
	<p>The system type supported by the power meter includes the five types: 1P2W, 2P3W, 3P3W, 3P4W, default is 3P4W.</p> <p>Press button 4 for 3 second to enter the setting state, and the character of the setting becomes the flashing state.</p> <p>Click button 2 or button 3 to scroll the page and select the next setting interface.</p> <p>Click button 1 to exit the setting menu and return to the previous setting screen.</p>
	<p>Click button 2 or button 3 to select the system type.</p> <p>Press button 4 for 3 second to confirm the setting. The meter will save the setting value and exit the setting state.</p> <p>Click button 1 to exit the setting state without saving the setting parameters.</p>
<h2>3. Setting user password</h2>	
	<p>User password setting range:0000 to 9999, default is 0000.</p> <p>Press button 4 for 3 second to enter the setting state, and the digit of the setting becomes the flashing state.</p> <p>Click button 2 or button 3 to scroll the page and select the next setting interface.</p> <p>Click button 1 to exit the setting menu and return to the previous setting screen.</p>
	<p>Click button 2 or button 3 to increase or decrease the number of set bits.</p> <p>Click button 4 can be moved the set bits to the right.</p> <p>Press button 4 for 3 second to confirm the setting. The meter will save the setting value and exit the setting state.</p> <p>Click button 1 to exit the setting state without saving the setting parameters.</p>
<h2>4. Reset Max. demand or historical electricity consumption log</h2>	
	<p>Press button 4 for 3 second to enter the reset state.</p> <p>Click button 2 or button 3 to scroll the page and select the next setting interface.</p> <p>Click button 1 to exit the setting menu and return to the previous setting screen.</p>
	<p>Click button 2 or button 3 to select the reset options.</p> <p>Press button 4 for 3 second to confirm the reset. The meter will reset the selected option and exit the reset state.</p> <p>Click button 1 to exit the reset state without reset the selected option.</p>
<p>Note:</p>	

LEG is mean: Historical monthly and historical daily consumption of energy. (this option is supported only for the Multit-tariff meter)

dnd is mean: Max. demand.

4.5.3. Set pulse output class parameters

Pulse output class parameters include: pulse output type, pulse output rate and pulse output width.

1. After entering the "Parameter Setting Menu" screen, select the setting screen (as shown in the figure below), and then press button 4 for 3 second to enter the pulse output class parameter setting screen.

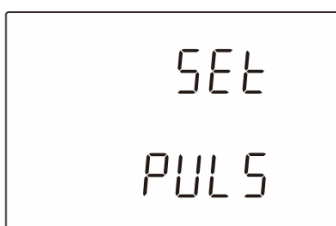

2. Setting pulse output type

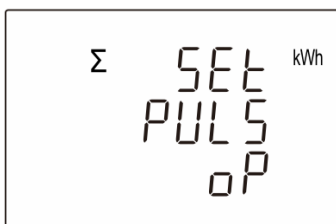

The type of energy represented by the pulse output.
Options that can be set: total active energy, import active energy, export active energy, total reactive energy, import reactive energy, export reactive energy, default is total active energy.

Press button 4 for 3 second to enter the setting state, and the character of the setting becomes the flashing state.
Click button 2 or button 3 to scroll the page and select the next setting interface.

Click button 1 to return to the previous level setup menu.

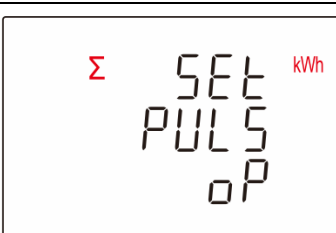

Click button 2 or button 3 to select the pulse output type.
Press button 4 for 3 second to confirm the setting. The meter will save the setting value and exit the setting state.

Click button 1 to exit the setting state without saving the setting parameters.

3. Setting pulse constant



Pulse constant can be set: 1, 10, 100, 400 imp/kWh(kvarh), default is 400 imp/kWh(kvarh).

Press button 4 for 3 second to enter the setting state, and the digit of the setting becomes the flashing state.

Click button 2 or button 3 to scroll the page and select the next setting interface.

Click button 1 to return to the previous level setup menu.

Note: The pulse constant cannot be set to 400 when the pulse width



	<p>time is equal to 200ms.</p> <p>Click button 2 or button 3 to select the pulse constant. Press button 4 for 3 second to confirm the setting. The power meter will save the setting value and exit the setting state. Click button 1 to exit the setting state without saving the setting parameters.</p>
<p>4. Setting pulse output width</p>	
	<p>The pulse output width represents the effective duration of the pulse output. Options that can be set: 60, 100, 200, unit is ms, default is 100ms.</p> <p>Press button 4 for 3 second to enter the setting state, and the digit of the setting becomes the flashing state. Click button 2 or button 3 to scroll the page and select the next setting interface. Click button 1 to return to the previous level setup menu.</p> <p>Note: When the pulse constant is equal to 400 imp/kWh(kvarh), the pulse width time cannot be set to 200ms.</p>
	<p>Click button 2 or button 3 to select the pulse output width. Press button 4 for 3 second to confirm the setting. The power meter will save the setting value and exit the setting state. Click button 1 to exit the setting state without saving the setting parameters.</p>



Table 4-1: List of pulse output type

Character	Pulse output type	Character	Pulse output type	Character	Pulse output type
Σ kWh	Total active energy	IMP kWh	Import active energy	EXP kWh	Export active energy
Σ kvarh	Total reactive energy	IMP kvarh	Import reactive energy	EXP kvarh	Export reactive energy

4.5.4. Set demand class parameters

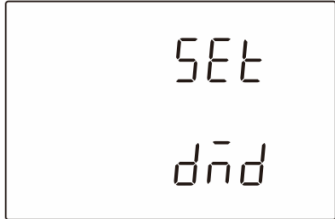
Demand class parameters include: demand interval period and sliding time.

<p>1. After entering the "Parameter Setting Menu" screen, select the setting screen (as shown in the figure below), and then press button 4 for 3 second to enter the demand class parameter setting screen.</p> 
<p>2. Setting demand interval period</p>

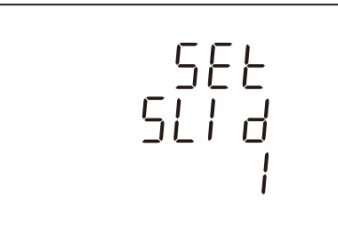
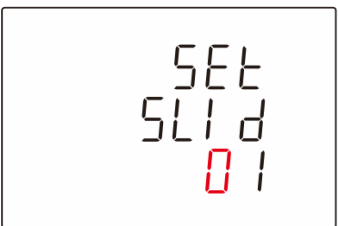



	<p>Demand interval period can be set: 0 to 60, unit is minute, default is 60 minutes.</p> <p>Press button 4 for 3 second to enter the setting state, and the digit of the setting becomes the flashing state.</p> <p>Click button 2 or button 3 to scroll the page and select the next setting interface.</p> <p>Click button 1 to return to the previous level setup menu.</p> <p>Note: If the demand interval period is set to 0 minutes, then the demand is updated every second.</p>
	<p>Click button 2 or button 3 to increase or decrease the number of set bits.</p> <p>Click button 4 can be moved the set bits to the right.</p> <p>Press button 4 for 3 second to confirm the setting. The meter will save the setting value and exit the setting state.</p> <p>Click button 1 to exit the setting state without saving the setting parameters.</p>
<h3>3. Setting sliding time</h3>	
	<p>Sliding time setting range: 1 to (demand interval period), unit is minutes, default is 1 minute.</p> <p>Press button 4 for 3 second to enter the setting state, and the digit of the setting becomes the flashing state.</p> <p>Click button 2 or button 3 to scroll the page and select the next setting interface.</p> <p>Click button 1 to return to the previous level setup menu.</p> <p>Note: The slip time has no effect when the demand interval period is set to 0.</p>
	<p>Click button 2 or button 3 to increase or decrease the number of set bits.</p> <p>Click button 4 can be moved the set bits to the right.</p> <p>Press button 4 for 3 second to confirm the setting. The meter will save the setting value and exit the setting state.</p> <p>Click button 1 to exit the setting state without saving the setting parameters.</p>

4.5.5. Set time class parameters

Time class parameters include: backlight time, automatic scroll display time, System time (RTC) and Tariff time.

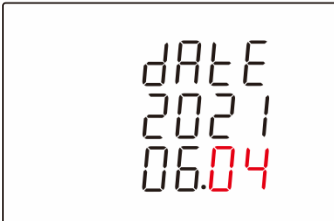
1. After entering the "Parameter Setting Menu" screen, select the setting screen (as shown in the figure below), and then press button 4 for 3 second to enter the time class parameter setting screen.

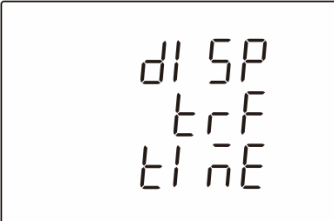
<h3>2. Setting backlight time</h3>	
	<p>Backlight time can be set: on, off, 5, 10, 30, 60, 120, unit is minute, default is 60 minutes.</p> <p>Press button 4 for 3 second to enter the setting state, and the character of the setting becomes the flashing state.</p> <p>Click button 2 or button 3 to scroll the page and select the next setting interface.</p> <p>Click button 1 to return to the previous level setup menu.</p> <p>Note:</p> <ol style="list-style-type: none"> 1. The character “on” means the backlight is always on, and “off” means the backlight is always off. 2. If you need to setting other values within 120 minutes, use the communication command to do so.
	<p>Click button 2 or button 3 to select the backlight time.</p> <p>Press button 4 for 3 second to confirm the setting. The power meter will save the setting value and exit the setting state.</p> <p>Click button 1 to exit the setting state without saving the setting parameters.</p> <p>Note: <i>oN</i> That means is on. <i>oFF</i> That means is off.</p>
<h3>3. Setting automatic scroll display time</h3>	
	<p>Automatic scroll display time set range: 0 to 60, unit is second, default is 0 second.</p> <p>Press button 4 for 3 second to enter the setting state, and the digit of the setting becomes the flashing state.</p> <p>Click button 2 or button 3 to scroll the page and select the next setting interface.</p> <p>Click button 1 to return to the previous level setup menu.</p> <p>Note: Automatic scroll display time is 0, means no automatic wheel display</p>
	<p>Click button 2 or button 3 to increase or decrease the number of set bits.</p> <p>Click button 4 can be moved the set bits to the right.</p> <p>Press button 4 for 3 second to confirm the setting. The power meter will save the setting value and exit the setting state.</p> <p>Click button 1 to exit the setting state without saving the setting parameters.</p>
<h3>4. Setting date of RTC (Only multitariff meter support this menu)</h3>	

	<p>Press button 4 for 3 second to enter the setting state, and the digit of the setting becomes the flashing state.</p> <p>Click button 2 or button 3 to scroll the page and select the next setting interface.</p> <p>Click button 1 to return to the previous level setup menu.</p>
	<p>Click button 2 or button 3 to increase or decrease the number of set bits.</p> <p>Click button 4 can be moved the set bits to the right.</p> <p>Press button 4 for 3 second to confirm the setting. The meter will save the setting value and exit the setting state.</p> <p>Click button 1 to exit the setting state without saving the setting parameters.</p>
<p>5. Setting system time (RTC)</p>	
	<p>Press button 4 for 3 second to enter the setting state, and the digit of the setting becomes the flashing state.</p> <p>Click button 2 or button 3 to scroll the page and select the next setting interface.</p> <p>Click button 1 to return to the previous level setup menu.</p>
	<p>Click button 2 or button 3 to increase or decrease the number of set bits.</p> <p>Click button 4 can be moved the set bits to the right.</p> <p>Press button 4 for 3 second to confirm the setting. The meter will save the setting value and exit the setting state.</p> <p>Click button 1 to exit the setting state without saving the setting parameters.</p>
<p>6. View tariff time</p>	
	<p>View menu for tariff information.</p> <p>Press button 4 for 3 second to enter the screen for veiw tariff information.</p> <p>Click button 2 or button 3 to scroll the page and select the next setting interface.</p> <p>Click button 1 to return to the previous level setup menu.</p> <p>Note: The menu cannot be setting and can only be viewed.</p>
	<p>The screen for displaying the tariff information.</p> <ol style="list-style-type: none"> 1. The number displayed in the first line of the screen represents the sequence number of the selected starting time point. The meter supports 8 starting time points and 4 tariff segments. 2. The character displayed in the second line of the screen represents the current tariff is T1. The meter supports 4 tariff segments. (T1 to T4) 3. The character displayed in the third line of the screen represents the starting time of the tariff segment (format is hours: minutes).

	<p><i>FEE1</i> That means tariff segment is tariff 1 (T1). <i>FEE2</i> That means tariff segment is tariff 2 (T2). <i>FEE3</i> That means tariff segment is tariff 3 (T3). <i>FEE4</i> That means tariff segment is tariff 4 (T4).</p> <p>Click button 1 scroll the page and select the next screen. Press button 1 for 3 second to exit the setting state without saving the setting parameters.</p> <p>Note: If FEE0 is displayed, the time segment is invalid and does not belong to any tariff.</p>
--	---

Appendix

Appendix A – LCD character definition table

0	1	2	3	4	5	6	7	8	9
A	B	C	D	E	F	G	H	I	J
K	L	M	N	O	P	Q	R	S	T
U	V	W	X	Y	Z				

Appendix B – Failure code reference table

No.	LCD display	Fault description
1	Err-01	The battery voltage is too low.

Appendix C – Alarm prompt comparison table

No.	The action of the meter	Alarm definition
1	LCD display alarm icon 	Occurs over voltage, over current or power exceeds the limit