

## Single-phase multifunction energy meter EXWI Series

User Guide V1.1



## Safety Information - Important Information

Read these instructions carefully and look at the equipment to become familiar with the device before trying to install, operate, service or maintain it. The following special messages may appear throughout this bulletin or on the equipment to warn of potential hazards or to call attention to information that clarifies or simplifies a procedure.



The addition of either symbol to a “Danger” or “Warning” safety label indicates that an electrical hazard exists which will result in personal injury if the instructions are not followed.



This is the safety alert symbol. It is used to alert you to potential personal injury hazards. Obey all safety messages that follow this symbol to avoid possible injury or death.

### **DANGER**

**DANGER** indicates an imminently hazardous situation which, if not avoided, will result in death or serious injury.

### **WARNING**

**WARNING** indicates a potentially hazardous situation which, if not avoided, can result in death or serious injury.

### **CAUTION**

**CAUTION** indicates a potentially hazardous situation which, if not avoided, can result in minor or moderate injury.

### **NOTICE**

**NOTICE** is used to address practices not related to physical injury. The safety alert symbol shall not be used with this signal word.

### **Please Note**

Electrical equipment should be installed, operated, serviced, and maintained only by qualified personnel. No responsibility is assumed by Nova for any consequences arising out of the use of this material.

A qualified person is one who has skills and knowledge related to the construction, installation, and operation of electrical equipment and has received safety training to recognize and avoid the hazards involved.

## Table of Contents

<b>Chapter 1. Overview</b> .....	- 1 -
1.1. Introduction.....	- 1 -
1.2. Characteristics .....	- 1 -
1.3. Parameters.....	- 1 -
<b>Chapter 2. Technical parameters specification</b> .....	- 2 -
2.1. Specification.....	- 2 -
2.2. Installation dimensions.....	- 4 -
2.3. Wiring Diagrams.....	- 4 -
<b>Chapter 3. General function description</b> .....	- 4 -
3.1. Multi-tariffs function.....	- 4 -
3.2. Demand calculation method.....	- 5 -
<b>Chapter 4. Operation</b> .....	- 5 -
4.1. Meter startup instructions .....	- 6 -
4.2. LCD display area description .....	- 6 -
4.3. Button definition description .....	- 7 -
4.4. Description of display screen .....	- 7 -
4.4.1. Main display screen.....	- 7 -
4.5. Setting-up .....	- 10 -
4.5.1. Set communication class parameters.....	- 10 -
4.5.2. Setting display class parameters.....	- 12 -
4.5.3. Setting time class parameters (Only multitariff meter support this menu).....	- 13 -
4.5.4. Setting user password.....	- 14 -
<b>Appendix</b> .....	- 16 -
Appendix A – LCD character definition table .....	- 16 -
Appendix B – Failure code reference table .....	- 16 -

## Chapter 1. Overview

### 1.1. Introduction

EXWI series products are single phase multi-function DIN rail installation energy meter. This series of products can support a variety of electric parameter measurement analysis, such as voltage, current, the four quadrant power parameters, power factor, etc. Meanwhile they can provide a variety of electrical energy parameters measurement, such as two-way active energy, reactive energy, monthly and daily energy consumption statistics. This series of products also can support the analysis of electric power parameter measurement in one phase two wires grid environment, is suitable for power monitoring for photovoltaic inverter, new energy electricity consumption statistic analysis, real time power monitoring and a variety of other environments, has the multi-function, high stability and long life characteristics. This series of products with RS485 communication interface, baud rate maximum support 19200bps, supporting Modbus communication protocols. It can easily realize the function of remote data read, and adopt the design of LCD and touch-sensitive key, which can easily carry out the local view and set operation of various parameters. The product has the function of password protection, which ensures the data security of the product. EXWI series products are multi-functional electric energy meters designed for electric energy monitoring of photovoltaic inverter, statistical analysis of new energy electricity consumption, power monitoring needs of power system utilities and intelligent buildings. Its complete communication function is very suitable for various control systems, SCADA systems and energy management systems.

### 1.2. Characteristics

- Maximum current 100A direct access
- DIN Rail mounting, standard 1 modulus width.
- Touch button design improves button operability and reduces button failure rate
- Multi-function parameter measurement, providing voltage, current, active power, reactive power, apparent power, power factor, phase Angle, etc.
- Provide a variety of statistical data and local storage functions, such as two-way power, demand and other statistical data. Provide monthly electricity consumption statistics for the last 12 months and daily electricity consumption statistics for the last 31 days
- supports the dual-timing function of the meter startup running time and load running time.
- Support RS485 communication function, baud rate up to 19200bps, support Modbus RTU.
- Supports one optocoupler pulse output interface, and output parameters can be set.
- LCD refresh time is 1 second, support manual or automatic scroll display (configurable)

### 1.3. Parameters

<b>1. The Unit can measure and display</b>	
<b>Instantaneous RMS Values</b>	
Current	Phase current
Voltage	L-N
Frequency	45 to 65Hz
Power	Active power, Reactive power, Apparent power
Power factor	Power factor

<b>Energy Values (include: import, export, import + export)</b>	
Active energy	0 to 999999.999 kWh (LCD display number of digits: 4+2 -> 5+1 -> 6+0)
Reactive energy	0 to 999999.999 kvarh (LCD display number of digits: 4+2 -> 5+1 -> 6+0)
Multi-Tariff active energy (T1 - T4)	0 to 999999.999 kWh (LCD display number of digits: 4+2 -> 5+1 -> 6+0)
<b>Maximum Demand Values</b>	
Max.Demand of power	Active power
<b>2. The Unit can measure and communication read</b>	
<b>Energy Values</b>	
Multi-Tariff active energy (T1 - T4)	0 to 999999.999 kWh, include: import, export, import+export
Multi-Tariff reactive energy (T1 - T4)	0 to 999999.999 kvarh, include: import, export, import+export
Monthly electricity consumption for the last 12 months	Total active energy Range: 0 to 999999.999 kWh
Daily energy consumption for the last 31 days	Total active energy Range: 0 to 999999.999 kWh
<b>Maximum Demand Values</b>	
Max.Demand of current	Phase current
Max.Demand of power	Active power, Reactive power, Apparent power
<b>3. The Unit can settable</b>	
Communication class	Modbus address, baud rate, parity bit, stop bit
System configuration class	User password (HMI)
Time class	Automatic scroll display time, Backlit time, System time (RTC), Tariff time

## Chapter 2. Technical parameters specification

### 2.1. Specification

<b>Electrical Characteristics</b>		
Type of measurement		RMS including harmonics on AC system, support Single Phase Two Wire
Measurement accuracy	Voltage, Current	Class 0.5, according IEC 61557-12
	Active power	Class 1 / 0.5, according IEC 61557-12
	Reactive power	Class 2, according IEC 61557-12
	Apparent power	Class 1, according IEC 61557-12
	Active energy	Class 1 / 0.5S, according IEC 62053-22, IEC 61557-12
	Reactive energy	Class 2, according IEC 62053-23, IEC 61557-12
	Power factor	Class 1, according IEC 61557-12
	Frequency	Class 0.2, according IEC 61557-12
Data update rate		1 second. Optional 100 ms
Input-Voltage	Rate voltage (Un)	230 Vac / 110 Vac (Option)
	Direct connection	Measured range: 176 to 275 Vac
	Frequency range	45 to 65 Hz
	Overload capacity	2*Un for 1 second
Input-Current	Measured range	0.005 to 100 A, basic current (Ib) is 5A
	Overload capacity	30*I <sub>max</sub> for 0.01 second
Real-time clock accuracy		0.5 s/d
<b>Mechanical Characteristics</b>		

IP Degree of Protection (IEC 60529)	Designed to IP51 front display, IP30 meter body
Dimensions (W x H x D)	18 x 116 x 72 mm
Mounting Position	DIN Rail mounting
Material of meter case	UL 94 V-0
<b>Environmental Characteristics</b>	
Operating Temperature	-25 to +55°C
Storage Temperature	-40 to +80°C
Humidity	< 90%, non-condensing
Pollution Degree	2
Altitude	Up to 2000m
Vibration	10 Hz to 150Hz, IEC 60068-2-6
<b>Electromagnetic Characteristics</b>	
Electrostatic Discharge	Level 4, according IEC 61000-4-2 <sup>(1)</sup>
Immunity to Radiated Fields	Level 3, according IEC 61000-4-3 <sup>(1)</sup>
Immunity to Electrical Fast Transients	Level 4, according IEC 61000-4-4 <sup>(1)</sup>
Immunity to Surges	Level 4, according IEC 61000-4-5 <sup>(1)</sup>
Immunity to Conducted Disturbances	Level 3, according IEC 61000-4-6 <sup>(1)</sup>
Immunity to Magnetic Fields	IEC 61000-4-8 <sup>(1)</sup>
Immunity to Voltage Dips	IEC 61000-4-11 <sup>(1)</sup>
Radiated Emissions	Class B, according EN55011
Conducted Emissions	Class B, according EN55011
Harmonics	IEC 61000-3-2 <sup>(1)</sup>
(1): The experimental test is carried out according to the grade requirements of industrial grade products in IEC61326-1	
<b>Safety</b>	
Measurement Category	CAT III, according IEC 61010-1
Overvoltage Category	CAT III, according IEC 61010-1
Insulation	AC Voltage Test: 4kV for 1 minute
	Impulse Voltage Test: 6kV - 1.2/50µs waveform
Protective Class	II, according IEC61010-1
<b>Communications</b>	
Interfaces standard and protocols	2-wire RS485, Modbus RTU Optional: MBus
Baud rate	1200 to 19200 bps, default is 9600 bps
Parity bit	None, Even, Odd, default is None
Stop bit	1 or 2, default is 1
Response time	<100ms
Transmission mode	half-duplex
Transmission distance	Up to 1000m
Max. Bus loading	64 pcs

## 2.2. Installation dimensions

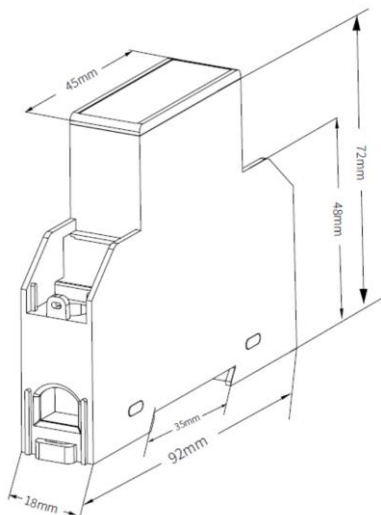

Dimensions without terminal cover

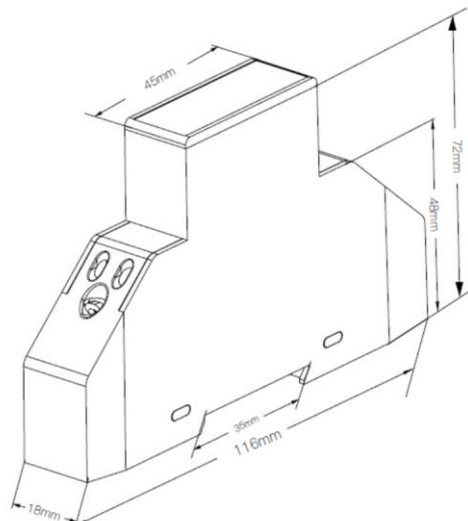

Dimensions with terminal cover

## 2.3. Wiring Diagrams

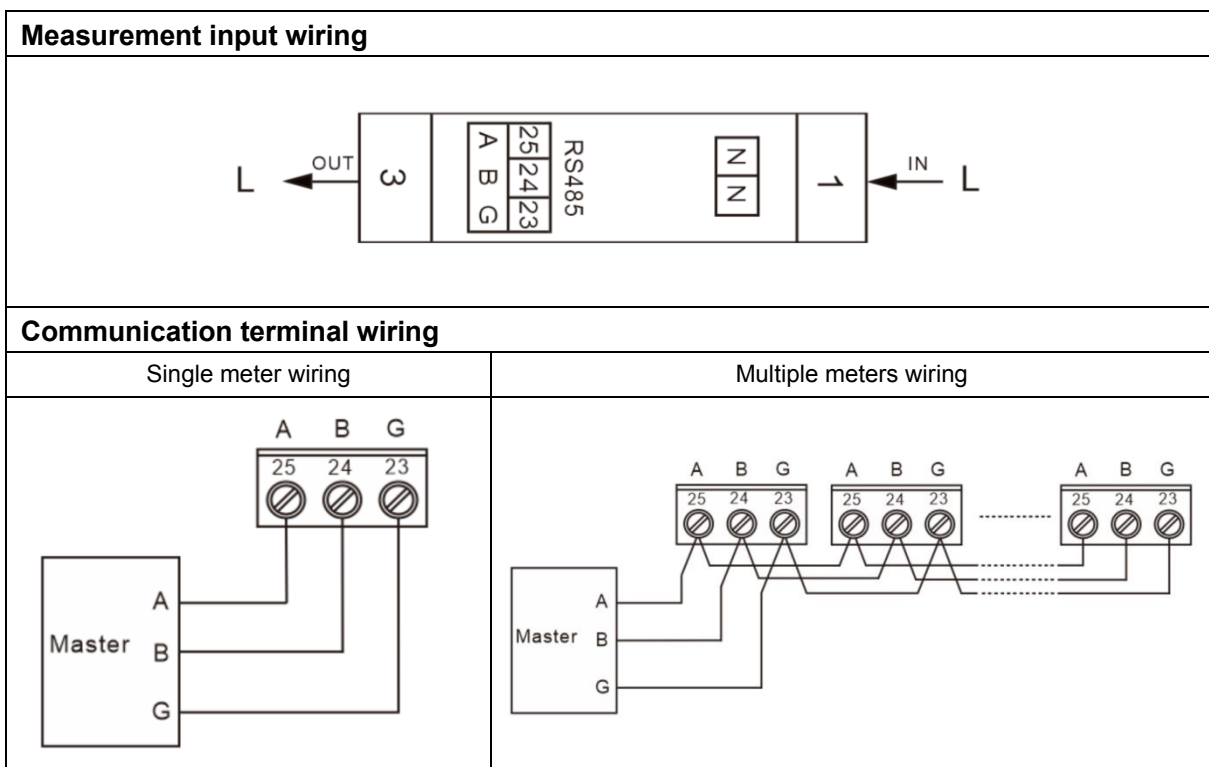

## Chapter 3. General function description

### 3.1. Multi-tariffs function

The multi-tariffs function refers to the function that the meter realizes time-sharing measurement of electric quantity. The power meter divides the 24 hours of a day into several time periods, and then specifies the rate number for each time period. Then the power meter accumulates the amount of electricity in time division according to the pre-divided time period, and stores it to the position of

the rate number corresponding to each time period, so as to realize the function of time-division measurement of electricity.

The meter used the method of the tariff number correlation to the starting time point to realize the tariff segment division. The power meter support up to 8 starting time points and up to 4 tariff segments (T1, T2, T3 and T4).

Figure 3-1: The starting time points of the tariff segment

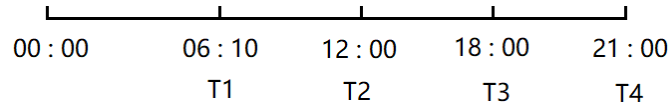

As shown in Figure 3-1, 06:10 designated as the start time of tariff 1 (T1), 12:00 designated as the start time of tariff 2 (T2), 18:00 designated as the start time of tariff 3 (T3), 21:00 designated as the start time of tariff 4 (T4), so tariff 1 time range is 06:10 to 12:00, tariff 2 time range is 12:00 to 18:00, tariff 3 time range is 18:00 to 21:00, tariff 4 time range is 21:00 to tomorrow 06:10.

Note: The tariff parameters can be set by communication commands (Please refer to the relevant communication protocol document for the register address).

### 3.2. Demand calculation method

The block intervals are sliding, the power meter calculates and update the demand at the sliding speed.

Figure 3-2: Diagram of sliding block interval calculation method

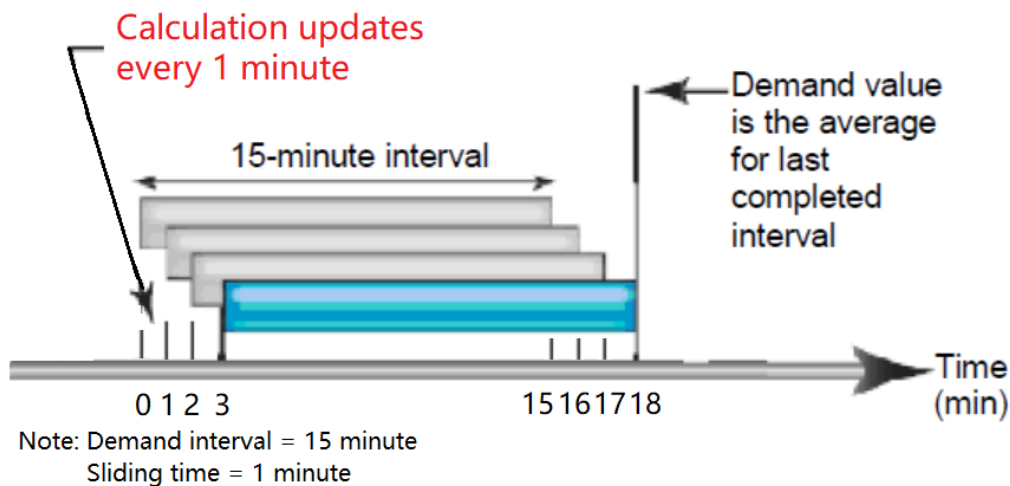



As shown in Figure 3-2, the first demand calculation is made at the 15th minute, and the demand calculation data is between the 0th and the 15th minute. At the 16th minute, do the second demand calculation, and the demand calculation data is between the 1th and the 16th minute. At the 17th minute, do the third demand calculation, and the demand calculation data is between the 2th and the 17th minute.

## Chapter 4. Operation

## 4.1. Meter startup instructions

After the EXWI series products are properly wired and connected to the power supply, the products will first enter the self-test process, under which the LCD screen display sequence is shown as follows:

First screen display	Display full screen characters	
Second screen display	Displays the software version number of the power meter	

## 4.2. LCD display area description

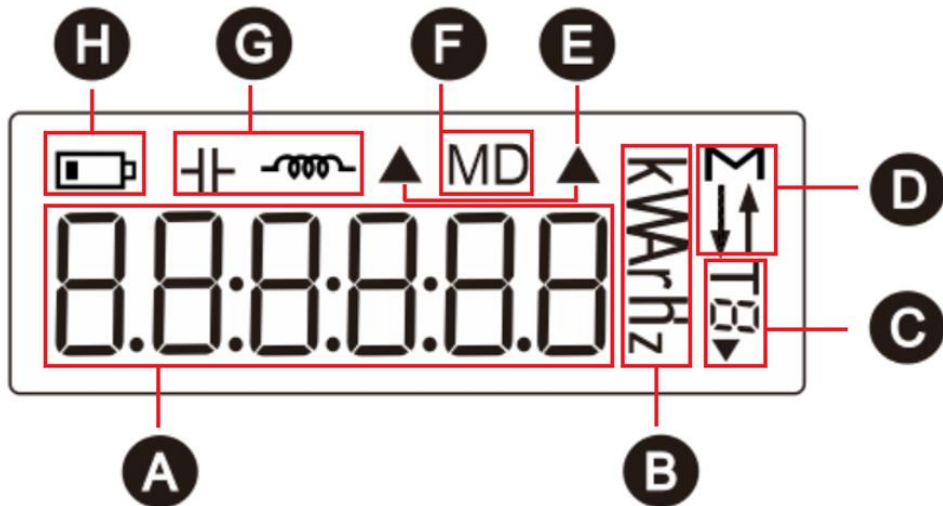

A: Measured values.

B: An icon of a unit of measurement data.

C: Multi tariff icon indicating the tariff segment to which the current energy. ▶ represents the tariff number displayed as the running tariff segment. For example: T2 ▶ The figure on the left represents that the tariff 2 (T2) segment is running, and the accumulated energy will be counted into the corresponding energy area of tariff 2 (T2).

D: Sum icon, direction icon for import and export, M mean that the data currently displayed is the sum parameter, ↓ mean import, ↑ mean export.

E: Auxiliary display icon.

F: Maximum demand icon.

G: Display icon of the load feature.

H: Battery status Icon displays the battery status, indicates that the battery is in a low voltage state.



## 4.3. Button definition description









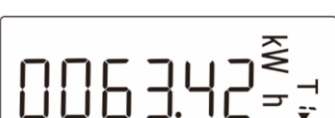
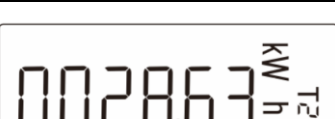
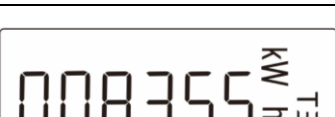
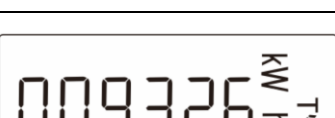

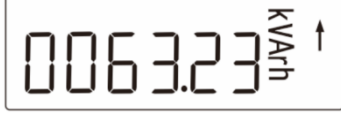

Button	Definition	Click	Press 2 second	Press 5 second
	Button 1	Scroll the page of the displayed page.	In the setting interface, move the setting cursor (the character position in the setting state).	Confirm the setting operation or enter the setting state.











## 4.4. Description of display screen

### 4.4.1. Main display screen

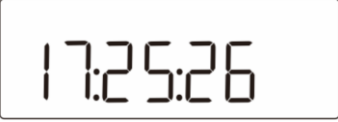
After the meter is powered on and passes the self-test process, the interface entered is defined as the main display interface, which is used to display the main measurement parameters, electric quantity data, instrument information and other data of the product. Users can scroll the display page by pressing the button 1.

LCD display	Description
	Total active energy Example: Total active energy = 738.59kWh
	Import active energy Example: Import active energy = 30.09kWh
	Export active energy Example: Export active energy = 708.50kWh
	Tariff 1 active energy Example: Tariff 1 active energy = 63.42kWh
	Tariff 2 active energy Example: Tariff 2 active energy = 28.63kWh
	Tariff 3 active energy Example: Tariff 3 active energy = 83.55kWh
	Tariff 4 active energy Example: Tariff 4 active energy = 93.26kWh

	Note: Only mult-tariff meter show this page
	Total reactive energy Example: Total reactive energy = 2363.49kvarh
	Import reactive energy Example: Import reactive energy = 2300.26kvarh
	Export reactive energy Example: Export reactive energy = 63.23kvarh
	Voltage Example: Voltage = 230.0V  is mean : The load is an inductive load
	Current Example: Current = 5.000A  is mean : The load is an inductive load
	Active power Example: Active power = 1.618kW  is mean : The load is an inductive load
	Reactive power Example: Reactive power = 15.13var ⊕ is mean : The load is a capacitive load ↑ is mean: The reactive power is export power (i.e. the power value is negative)
	Apparent power Example: Apparent power = 1.592kVA ⊕ is mean : The load is a capacitive load
	Power factor Example: Power factor = 0.986  is mean : The load is an inductive load

	<p>↑ is mean: The power factor is export. (i.e. the power factor value is negative)</p>
	<p>Frequency</p> <p>Example: Frequency = 50.03Hz</p> <p> is mean : The load is an inductive load</p>
	<p>Maximum active power demand</p> <p>Example: Maximum active power demand = 1.740kW</p>
	<p>Displaying the current date of the system real-time clock.</p> <p>Example: The current date is March 11, 2021</p> <p>Note: Only mult-tariff meter show this page</p>
	<p>Displaying the current time of the system real-time clock.</p> <p>Example: The current time is 17:25.26</p> <p>Note: Only mult-tariff meter show this page</p>
	<p>Modbus address</p> <p>Example: The modbus address is 1.</p>
	<p>Baud rate</p> <p>Example: The baud rate is 9600bps.</p>
	<p>Parity bit</p> <p>Example: The Parity bit is None.</p> <p>Note: The value of E indicates Even, and the value of O indicates odd.</p>
	<p>Stop bit</p> <p>Example: The Stop bit is 1.</p>
	<p>Pulse output mode and pulse constant of optocoupler output channel.</p> <p>Example: The left figure represents the total active power in the pulse output mode, and the pulse constant is 1000 imp/kWh.</p>
	<p>Software version number</p>

## 4.5. Setting-up

The logical diagram of the parameter setting menu is as follows:

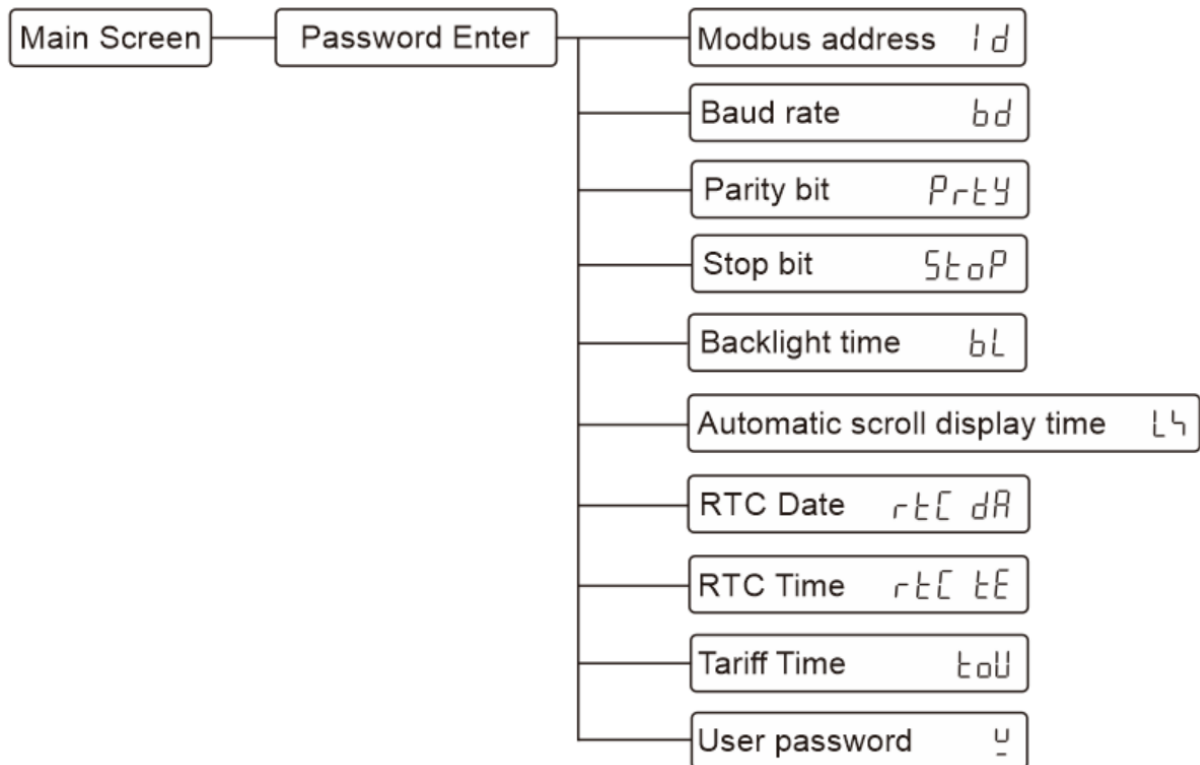

### How to enter the "Parameter setting Menu" screen:

Step 1: In the main display screen, press button 1 for 5 second to enter the user password input mode.



**Note:** The user password input screen is shown in the figure on the right.

Step 2: Enter the correct user password and press button 1 for 5 second to confirm.

### How to enter a password:

A: Click button 1 to increase or decrease the number of flashing bits.





B: Press button 1 for 2 second to move the flashing position to the right.



C: After entering the correct password, press button 1 for 5 second for confirmation. If the password is verified correctly, the power meter will enter the screen of "Parameter Setting menu".

Note: Under the user password input screen, if there is no button operation in more than 10 second under this screen, the meter will automatically return to the main display screen.

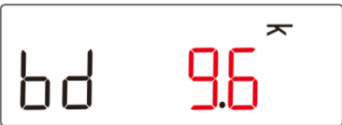
#### 4.5.1. Set communication class parameters



Communication parameters include: Modbus address, baud rate, parity bit, stop bit.

1. Setting the modbus communication address	
	<p>Modbus address setting range: 001 to 247, default is 001.</p> <p>Press button 1 for 5 second to enter the setting state, and the digit of the setting becomes the flashing state.</p> <p>Click button 1 to scroll the page and select the next setting interface. If there is no key operation for more than 10 seconds, you can exit the setup menu and return to the main display interface.</p>
	<p>Click button 1 to increase or decrease the number of set bits.</p> <p>Press button 1 for 2 second can be moved the set bits to the right.</p> <p>Press button 1 for 5 second to confirm the setting. The meter will save the setting value and exit the setting state.</p> <p>If there is no key operation for more than 10 seconds, you can exit the setting state without saving the setting parameters.</p>
2. Setting the baud rate	
	<p>Baud rate can be setting: 1200, 2400, 4800, 9600, 19200 bps, default is 19200bps.</p> <p>Press button 1 for 5 second to enter the setting state, and the digit of the setting becomes the flashing state.</p> <p>Click button 1 to scroll the page and select the next setting interface. If there is no key operation for more than 10 seconds, you can exit the setup menu and return to the main display interface.</p>
	<p>Click button 1 to select the baud rate.</p> <p>Press button 1 for 5 second to confirm the setting. The meter will save the setting value and exit the setting state.</p> <p>If there is no key operation for more than 10 seconds, you can exit the setting state without saving the setting parameters.</p>
3. Setting the parity bit	
	<p>Parity bit can be setting: None, Even, Odd, default is None.</p> <p>Press button 1 for 5 second to enter the setting state, and the character of the setting becomes the flashing state.</p> <p>Click button 1 to scroll the page and select the next setting interface. If there is no key operation for more than 10 seconds, you can exit the setup menu and return to the main display interface.</p>
	<p>Click button 1 to select the parity bit.</p> <p>Press button 1 for 5 second to confirm the setting. The meter will save the setting value and exit the setting state.</p> <p>If there is no key operation for more than 10 seconds, you can exit the setting state without saving the setting parameters.</p> <p>Note: <b>N</b> is mean None, <b>E</b> is mean Even, <b>O</b> is mean Odd.</p>
4. Setting the stop bit	

	<p>Stop bit can be setting: 1 or 2, default is 1.</p> <p>Press button 1 for 5 second to enter the setting state, and the digit of the setting becomes the flashing state.</p> <p>Click button 1 to scroll the page and select the next setting interface. If there is no key operation for more than 10 seconds, you can exit the setup menu and return to the main display interface.</p> <p><b>Note:</b> The stop bit can only be set to 2 if the check bit is equal to None.</p>
	<p>Click button 1 to select the stop bit.</p> <p>Press button 1 for 5 second to confirm the setting. The meter will save the setting value and exit the setting state.</p> <p>If there is no key operation for more than 10 seconds, you can exit the setting state without saving the setting parameters.</p>

#### 4.5.2. Setting display class parameters

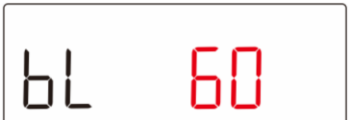



Display class parameters include: backlight time, automatic scroll display time.

<h3>2. Setting backlight time</h3>	
	<p>Backlight time can be set: on, off, 5, 10, 30, 60, 120, unit is minute, default is 60 minutes.</p> <p>Press button 1 for 5 second to enter the setting state, and the character of the setting becomes the flashing state.</p> <p>Click button 1 to scroll the page and select the next setting interface. If there is no key operation for more than 10 seconds, you can exit the setup menu and return to the main display interface.</p> <p>Note:</p> <ol style="list-style-type: none"> <li>1. The character “on” means the backlight is always on, and “off” means the backlight is always off.</li> <li>2. If you need to setting other values within 120 minutes, use the communication command to do so.</li> </ol>
	<p>Click button 1 to select the backlight time.</p> <p>Press button 1 for 5 second to confirm the setting. The meter will save the setting value and exit the setting state.</p> <p>If there is no key operation for more than 10 seconds, you can exit the setting state without saving the setting parameters.</p> <p><b>Note:</b> <i>on</i> That means is on. <i>off</i> That means is off.</p>
<h3>3. Setting automatic scroll display time</h3>	
	<p>Automatic scroll display time set range: 0 to 60, unit is second, default is 0 second.</p> <p>Press button 1 for 5 second to enter the setting state, and the digit of the setting becomes the flashing state.</p>

	<p>Click button 1 to scroll the page and select the next setting interface. If there is no key operation for more than 10 seconds, you can exit the setup menu and return to the main display interface.</p> <p><b>Note:</b> Automatic scroll display time is 0, means no automatic wheel display</p>
	<p>Click button 1 to increase or decrease the number of set bits. Press button 1 for 2 second can be moved the set bits to the right. Press button 1 for 5 second to confirm the setting. The meter will save the setting value and exit the setting state. If there is no key operation for more than 10 seconds, you can exit the setting state without saving the setting parameters.</p>

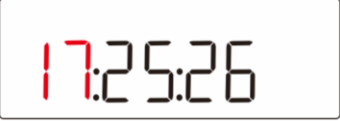

#### 4.5.3. Setting time class parameters (Only mult-tariff meter support this menu)

Time class parameters include: System time (RTC) and Tariff time.

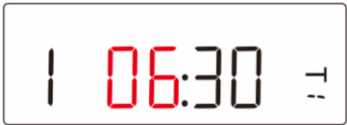
1. Setting date of RTC	
	<p>Press button 1 for 5 second to enter the setting state, and the digit of the setting becomes the flashing state. Click button 1 to scroll the page and select the next setting interface. If there is no key operation for more than 10 seconds, you can exit the setup menu and return to the main display interface.</p>
	<p>Click button 1 to increase or decrease the number of set bits. Press button 1 for 2 second can be moved the set bits to the right. Press button 1 for 5 second to confirm the setting. The meter will save the setting value and exit the setting state. If there is no key operation for more than 10 seconds, you can exit the setting state without saving the setting parameters.</p>
2. Setting system time (RTC)	
	<p>Press button 1 for 5 second to enter the setting state, and the digit of the setting becomes the flashing state. Click button 1 to scroll the page and select the next setting interface. If there is no key operation for more than 10 seconds, you can exit the setup menu and return to the main display interface.</p>
	<p>Click button 1 to increase or decrease the number of set bits. Press button 1 for 2 second can be moved the set bits to the right. Press button 1 for 5 second to confirm the setting. The meter will save the setting value and exit the setting state. If there is no key operation for more than 10 seconds, you can exit the setting state without saving the setting parameters.</p>
3. Setting tariff time (TOU)	
	<p>View menu for tariff information.</p> <p>Press button 1 for 5 second to enter the screen for veiw tariff information. Click button 1 to scroll the page and select the next setting interface. If there is no key operation for more than 10 seconds, you can exit</p>

	<p>the setup menu and return to the main display interface.</p> <p>Note: The menu cannot be setting and can only be viewed.</p>
	<p>The screen for displaying the tariff information.</p> <ol style="list-style-type: none"> <li>1. The number displayed of the screen represents the sequence number of the selected starting time point. The meter supports 8 starting time points and 4 tariff segments.</li> <li>2. The leftmost number on the screen represents the sequence number of time segment.</li> <li>3. The character "06:30" on the of the screen represents the starting time of the tariff segment (format is hours: minutes)</li> <li>4. T1 in the lower rightcorner of the screen indicates that the current tariff is T1. The meter supports 4 tariff segments. (T1 to T4)</li> </ol> <p>Click button 1 scroll the page and select the next screen. Press button 1 for 5 second to enter the setting state, and the digit of the setting becomes the flashing state. If there is no key operation for more than 10 seconds, you can exit to view the status and return to the upper-level setting menu.</p> <p>Note: If T0 is displayed, the time segment is invalid and does not belong to any tariff.</p>
	<p>The screen for setting the tariff information.</p> <p>Click button 1 to increase or decrease the number of set bits. Press button 1 for 2 second can be moved the set bits to the right. Press button 1 for 5 second to confirm the setting. The meter will save the setting value and exit the setting state. If there is no key operation for more than 10 seconds, you can exit the setting state without saving the setting parameters.</p>

#### 4.5.4. Setiting user password

1. Setting user password	
	<p>User password setting range:0000 to 9999, default is 0000.</p> <p>Press button 1 for 5 second to enter the setting state, and the digit of the setting becomes the flashing state. Click button 1 to scroll the page and select the next setting interface. If there is no key operation for more than 10 seconds, you can exit the setup menu and return to the main display interface.</p>
	<p>Click button 1 to increase or decrease the number of set bits. Press button 1 for 2 second can be moved the set bits to the right. Press button 2 for 5 second to confirm the setting. The meter will save the setting value and exit the setting state. If there is no key operation for more than 10 seconds, you can exit the setting state without saving the setting parameters.</p>

## Appendix

Appendix A – LCD character definition table

0	1	2	3	4	5	6	7	8	9
A	B	C	D	E	F	G	H	I	J
K	L	M	N	O	P	Q	R	S	T
U	V	W	X	Y	Z				

Appendix B – Failure code reference table

No.	LCD display	Fault description
1	Err-01	The battery voltage is too low.